

# Quick Size Reference

First-Class Mail Domestic—Retail

## POSTCARDS

	min.	max.
LENGTH	5"	6"
HEIGHT	3 1/2"	4 1/4"
THICKNESS	.007"	.016"

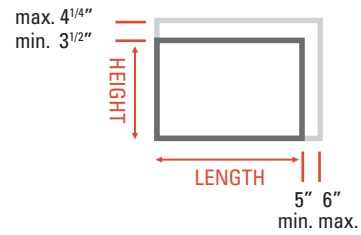

## LETTERS

	min.	max.
LENGTH	5"	11 1/2"
HEIGHT	3 1/2"	6 1/8"
THICKNESS	.007"	.25"

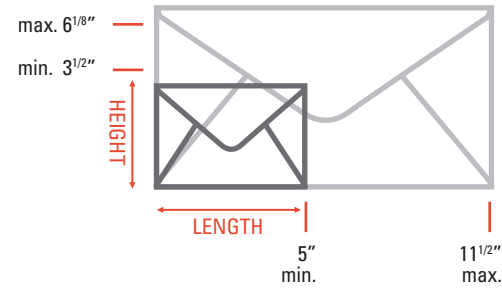

### ASPECT RATIO

The length of the mailpiece divided by height. It must be between 1.3 and 2.5, inclusive.

## LARGE ENVELOPES / FLATS

	min.*	max.
LENGTH	11 1/2"	15"
HEIGHT	6 1/8"	12"
THICKNESS	.25"	.75"

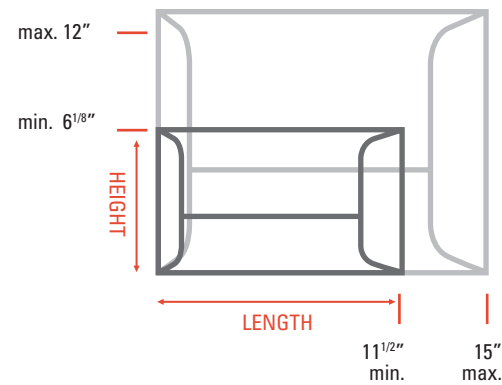

\* Flats exceed at least one of these dimensions.



# Postal Rates

SPC PROUDLY SUPPORTS THE ENVIRONMENT THROUGH THESE ASSOCIATIONS



Printed on McCoy Gloss 80# Cover Recycled Stock.

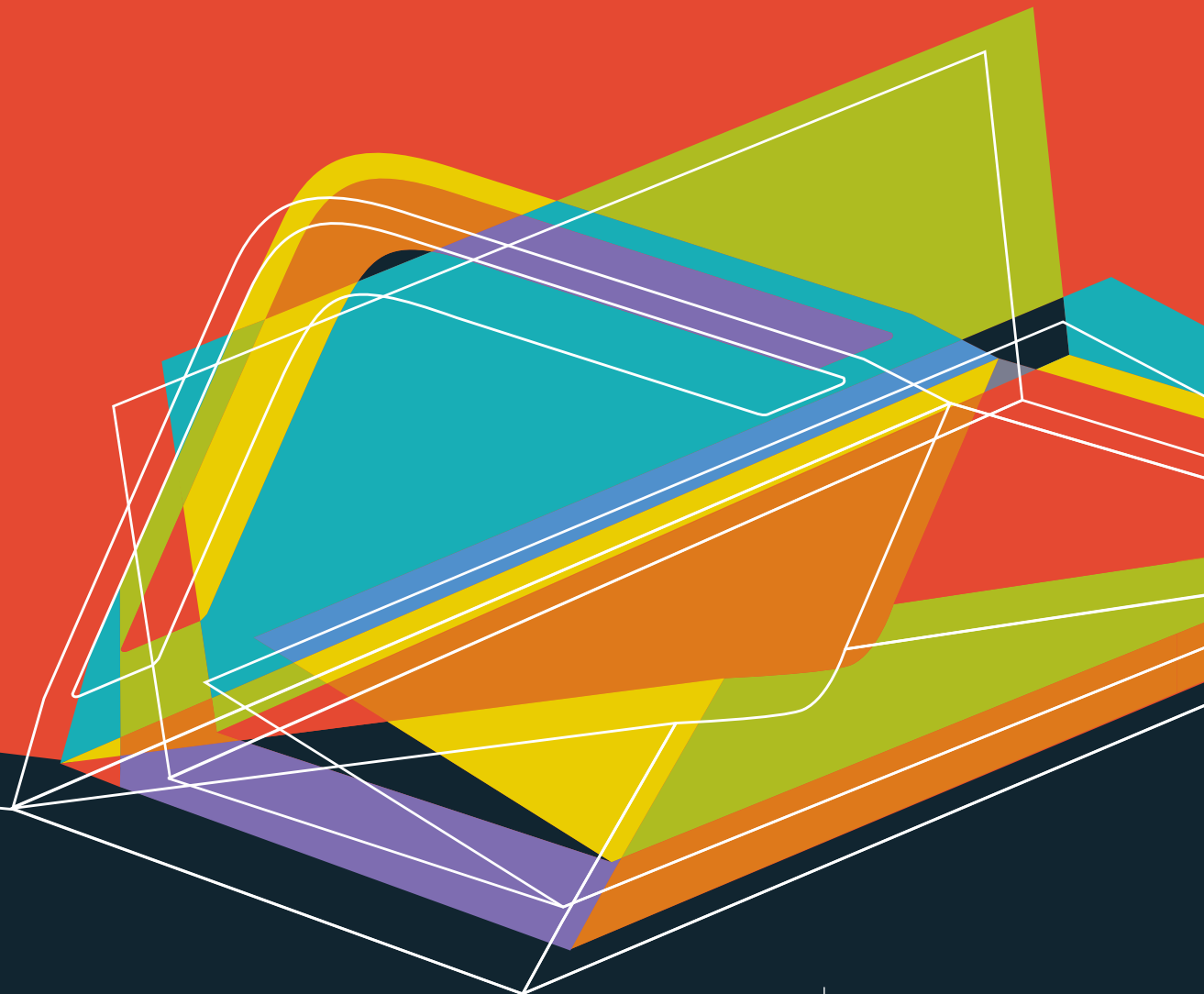

### SPECIALTY PRINT COMMUNICATIONS

6019 WEST HOWARD STREET. NILES, ILLINOIS 60714  
 847 588 2580  
 SPECIALTYPRINTCOMM.COM

© 2010 Specialty Print Communications. All rights reserved.



# First Class Mail

EFFECTIVE JANUARY 4, 2010

## COMMERCIAL & RETAIL LETTERS & CARDS

Weight Not Over (ounces)	COMMERCIAL				RETAIL			
	AUTOMATION <sup>1</sup>				NONAUTOMATION	LETTERS AND CARDS <sup>1</sup>	LARGE ENVELOPES <sup>2</sup>	PACKAGES <sup>3</sup>
	5-Digit	3-Digit	AADC	Mixed AADC	Presorted <sup>2</sup>			
1	\$.335	\$.357	\$.360	\$.382	\$.414	\$.44	\$.88	\$ 1.22
2	.460	.482	.485	.507	.539	.61	1.05	1.39
3	.585	.607	.610	.632	.664	.78	1.22	1.56
3.5	.710	.732	.735	.757	.789 <sup>3</sup>	.95	--	--
Postcard <sup>4</sup>	.205	.218	.220	.230	.245	.28 <sup>5</sup>	--	--

1. Subtract \$0.003 for each auto letter/card that complies with the full-service Intelligent Mail option requirements.
2. Letters that meet one or more of the nonmachinable characteristics in DMM 201.2.1 are subject to the \$0.20 nonmachinable surcharge.
3. The maximum weight for machinable letter preparation is 3.3 ounces.
4. The card price applies to each single or double postcard when originally mailed; reply half of double postcard-sized mail piece must be designed for reply mail purposes only.

1. Letters that meet one or more of the nonmachinable characteristics in DMM 101.1.2 are subject to the \$.20 nonmachinable surcharge.
2. Large envelope-sized pieces that are rigid, nonrectangular, or not uniformly thick pay package prices.
3. For keys and identification devices, add \$.74. If more than 13 ounces, see Priority Mail prices.
4. For weights over 3.5 ounces, see large envelope (flat) prices.
5. The card price applies to each single or double postcard sized mailpiece when originally mailed; reply half of double postcard must be designed for reply mail purposes only.

## COMMERCIAL FLATS

Weight Not Over (ounces) <sup>1</sup>	AUTOMATION <sup>2</sup>				NONAUTOMATION
	5-Digit	3-Digit	ADC	Mixed ADC	Presorted
1	\$.380	\$.542	\$.603	\$0.725	\$.757
2	.550	.712	.773	0.895	.927
3	.720	.882	.943	1.065	1.097
4	.890	1.052	1.113	1.235	1.267
5	1.060	1.222	1.283	1.405	1.437
6	1.230	1.392	1.453	1.575	1.607
7	1.400	1.562	1.623	1.745	1.777
8	1.570	1.732	1.793	1.915	1.947
9	1.740	1.902	1.963	2.085	2.117
10	1.910	2.072	2.133	2.255	2.287
11	2.080	2.242	2.303	2.425	2.457
12	2.250	2.412	2.473	2.595	2.627
13	2.420	2.582	2.643	2.765	2.797

1. Flat-size pieces with certain characteristics (see DMM 301.1.3 and 301.1.4) are subject to parcel prices.
2. Subtract \$0.003 for each automation flat that complies with the full-service Intelligent Mail option requirements.

# Standard Mail Regular

EFFECTIVE JANUARY 4, 2010

## COMMERCIAL LETTERS CARRIER ROUTE & AUTOMATION

	Entry Discount	CARRIER ROUTE <sup>1,2</sup>			AUTOMATION <sup>2</sup>			
		Saturation	High Density	Basic	5-Digit	3-Digit	AADC	Mixed AADC
Letters weighing 3.3 oz. or less	None	\$.182	\$.193	\$.262	\$.233	\$.251	\$.253	\$.270
	DBMC	.148	.159	.228	.199	.217	.219	.236
	DSCF	.139	.150	.219	.190	.208	.210	...
per piece price	DDU	--	--	--	...	...	...	...
more than 3.3 oz. <sup>3</sup>	None	.609	.649	.696	.725	.725	.725	.725
	DBMC	.446	.486	.533	.562	.562	.562	.562
per pound price	DSCF	.401	.441	.488	.517	.517	.517	...
	DDU	--	--	--	...	...	...	...
+ per piece price		+.056 <sup>4</sup>	+.059 <sup>4</sup>	+.118 <sup>4</sup>	+.083 <sup>4</sup>	+.101 <sup>4</sup>	+.103 <sup>4</sup>	+.120 <sup>4</sup>

1. Carrier route letters that are not automation-compatible and barcoded (DMM 201.3.0) are available at the flat-size prices (DMM 243.6.0). Mailers may not pay carrier route flat prices and claim the DDU discount for letter-size pieces.
2. Subtract \$0.001 for each letter that complies with the full-service Intelligent Mail option requirements.
3. For pieces weighing more than 3.3 ounces, each piece is subject to both a per piece price and a per pound price. Multiply the number of pieces in the mailing by per piece price. Multiply the number of pounds of the mailing by per pound price. Add both totals.
4. Per piece price for carrier route letters and automation letters that weigh more than 3.3 ounces but less than (or equal to) 3.5 ounces includes a discount that equals the applicable flat-size price (3.3 ounces or less) minus the applicable letter piece price (3.3 ounces or less).

## COMMERCIAL LETTERS NONAUTOMATION

	Entry Discount	MACHINABLE		NONMACHINABLE <sup>1</sup>			
		AADC	Mixed AADC	5-Digit	3-Digit	ADC	Mixed ADC
Letters weighing 3.3 oz. or less	None	\$.256	\$.273	\$.330	\$.447	\$.491	\$.578
	DBMC	.222	.239	.296	.413	.457	.544
	DSCF	.213	...	.287	.404	.448	...
per piece price	DDU	....	...	...	...	...	...

1. For pieces over 3.3 ounces, see Standard Mail Nonautomation Flat prices.

## COMMERCIAL FLATS CARRIER ROUTE, AUTOMATION & NONAUTOMATION

	Entry Discount	CARRIER ROUTE <sup>1,2</sup>			AUTOMATION <sup>1,2</sup>				NONAUTOMATION <sup>1</sup>			
		Saturation <sup>3</sup>	High Density	Basic	5-Digit	3-Digit	ADC	Mixed ADC	5-Digit	3-Digit	ADC	Mixed ADC
Flats weighing 3.3 oz. or less	None	\$.194	\$.219	\$.262	\$.346	\$.418	\$.486	\$.496	\$.367	\$.464	\$.509	\$.558
	DBMC	.160	.185	.228	.312	.384	.452	.462	.333	.430	.475	.524
	DSCF	.151	.176	.219	.303	.375	.443	...	.324	.421	.466	...
per piece price	DDU	.142	.167	.210	...	...	...	...	...	...	...	...
more than 3.3 oz. <sup>4</sup>	None	.609	.609	.696	.725	.725	.725	.725	.725	.725	.725	.725
	DBMC	.446	.446	.533	.562	.562	.562	.562	.562	.562	.562	.562
per pound price	DSCF	.401	.401	.488	.517	.517	.517	...	.517	.517	.517	...
	DDU	.356	.356	.443	...	...	...	...	...	...	...	...
+ per piece price		+.068	+.093	+.118	+.196	+.268	+.336	+.346	+.217	+.314	+.359	+.408

1. Flat-size pieces with certain characteristics (see DMM 301.1.3 and 301.1.4) are subject to not flat-machinable or parcel prices.
2. Subtract \$.001 for each flat that complies with the full-service Intelligent Mail option (not available for Saturation) requirements.
3. For carrier route flats with a detached address label, add \$.017 per piece.
4. For pieces weighing more than 3.3 ounces, each piece is subject to both a per piece price and a per pound price. Multiply the number of pieces in the mailing by per piece price. Multiply the number of pounds of the mailing by per pound price. Add both totals.

# Standard Mail NonProfit

EFFECTIVE JANUARY 4, 2010

## COMMERCIAL LETTERS CARRIER ROUTE & AUTOMATION

	Entry Discount	CARRIER ROUTE <sup>1,2</sup>			AUTOMATION <sup>2</sup>			
		Saturation	High Density	Basic	5-Digit	3-Digit	AADC	Mixed AADC
Letters weighing 3.3 oz. or less	None	\$.110	\$.121	\$.190	\$.132	\$.150	\$.152	\$.169
	DBMC	.076	.087	.156	.098	.116	.118	.135
	DSCF	.067	.078	.147	.089	.107	.109	--
per piece price	DDU	--	--	--	--	--	--	--
more than 3.3 oz. <sup>3</sup>	None	.439	.479	.526	.628	.628	.628	.628
	DBMC	.276	.316	.363	.465	.465	.465	.465
per pound price	DSCF	.231	.271	.318	.420	.420	.420	--
	DDU	--	--	--	--	--	--	--
+ per piece price		+.019 <sup>4</sup>	+.022 <sup>4</sup>	+.082 <sup>4</sup>	+.002 <sup>4</sup>	+.020 <sup>4</sup>	+.022 <sup>4</sup>	+.039 <sup>4</sup>

1. Carrier route letters that are not automation-compatible and barcoded (DMM 201.3.0) are available at the flat-size prices (DMM 243.6.6). Mailers may not pay carrier route flat prices and claim the DDU discount for letter-size pieces.
2. Subtract \$0.001 for each letter that complies with the full-service Intelligent Mail option requirements.
3. For pieces weighing more than 3.3 ounces, each piece is subject to both a per piece price and a per pound price. Multiply the number of pieces in the mailing by per piece price. Multiply the number of pounds of the mailing by per pound price. Add both totals.
4. Per piece price for carrier route letters and automation letters that weigh more than 3.3 ounces but less than (or equal to) 3.5 ounces includes a discount that equals the applicable flat-size price (3.3 ounces or less) minus the applicable letter piece price (3.3 ounces or less).

## COMMERCIAL LETTERS NONAUTOMATION

	Entry Discount	MACHINABLE		NONMACHINABLE <sup>1</sup>		
		AADC	Mixed AADC	5-Digit	3-Digit	ADC
Letters weighing 3.3 oz. or less	None	\$.155	\$.172	\$.229	\$.346	\$.390
	DBMC	.121	.138	.195	.312	.356
	DSCF	.112	...	.186	.303	.347
per piece price	DDU	....	...	...	...	...

1. For pieces over 3.3 ounces, see Standard Mail Nonautomation Flat prices.

